

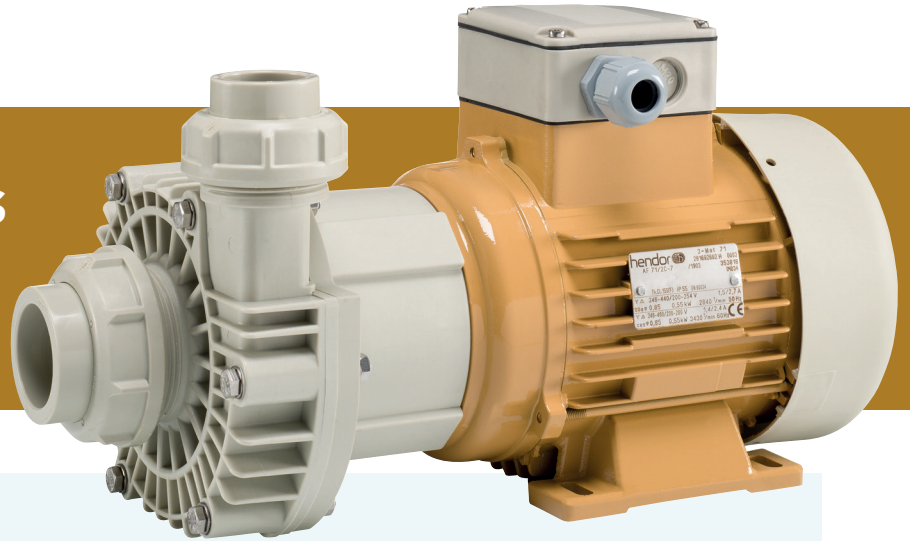

## HORIZONTAL PUMPS

### Magnetic drive Series MXH



MXH150-PP

**6000 - 15000 l/h**

100 - 250 l/min

The newest and most advanced magnetic drive pump in the Hendor product range. Standard equipped with SiC/SiC bearings. Magnetic drive centrifugal pumps are sealless and therefore leak free and safe for people, environment and equipment.

The MXH series combines maximum hydraulic efficiency with a robust, compact and reliable construction. This results in maximum installation uptime and a long service life, providing best in class performance, technically and economically. The MXH series is designed and manufactured for transfer and circulation of chemicals. Easy to build-in and -out, specially for OEM configurations.

#### Features

- Magnetic drive
- Sealless, 100% leak free
- SiC/SiC bearings
- Including complete +GF+ union ends
- EPDM elastomers for PP and FPM for PVDF
- Max. temperature PP 80°C, PVDF 100°C
- Stainless steel fasteners and type shields
- Extra strong neodymium magnets
- Single stage operation
- High quality European, purpose designed electric motor:
  - 3 phase, 50/60 Hz, 2900/3500 rpm, IP55, multi voltage
  - with double layer 2C chemical resistant coating
  - suitable for frequency drive control

#### Options

- Hose connections
- Union sockets in PVC or CPVC
- Specific elastomers
- Dry run protection
- Priming chamber
- Electric motor options:
  - motor mounted frequency drive
  - EMC compatibility
  - PTC thermistor
  - thermal overload incl. switch and lead
  - single phase
  - specific voltages
  - electrical lead (4 m)
  - other RAL colours

Type	Material	Q max (l/h)	H max (m)	Motor		I nom. (A) 400V-50Hz	In (d/DN)	Out (d/DN)	Net weight (kg)	
				kW	HP				PP	PVDF
MXH150	PP/PVDF	15000	13,5	0,55	3/4	1,5	40/32	32/25	10	11

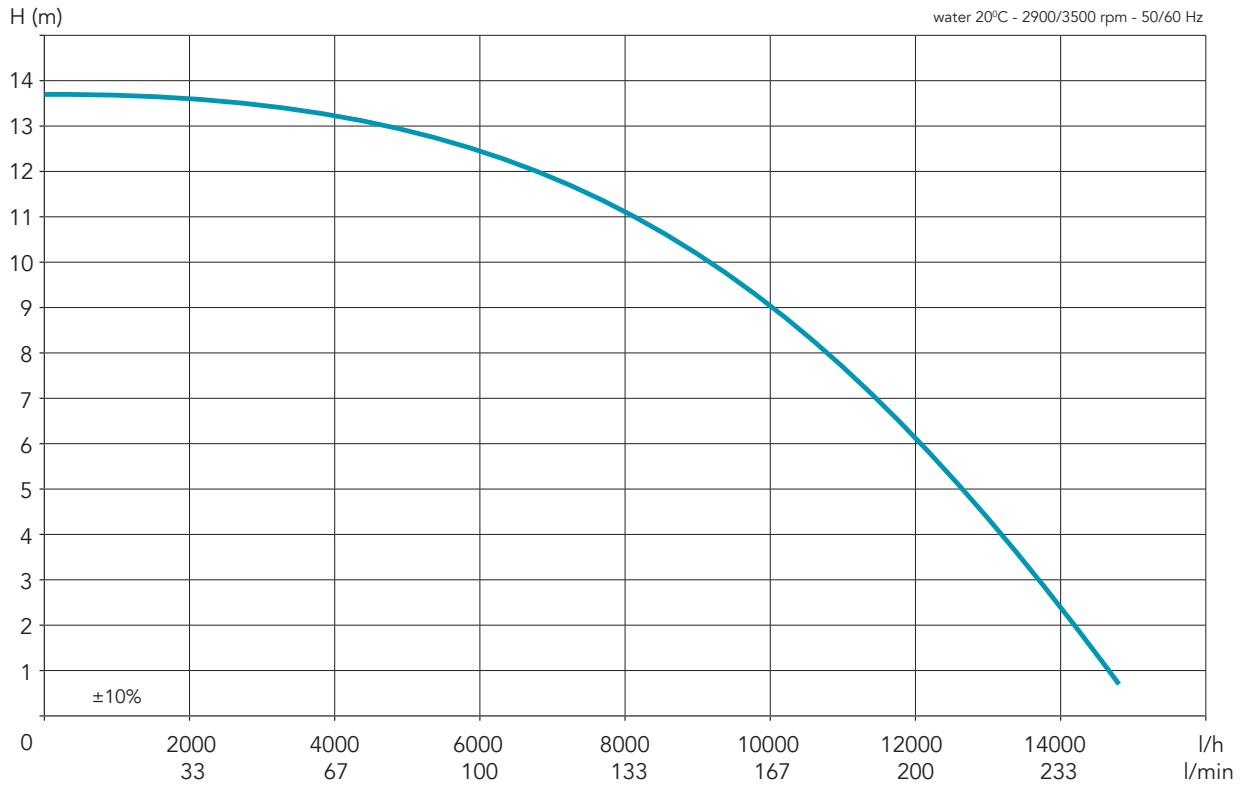

Exploded view

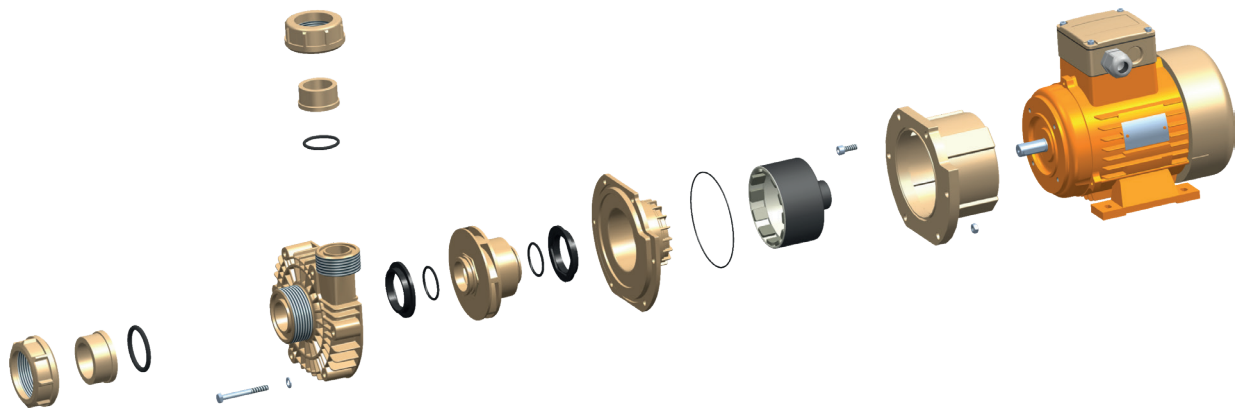

Dimensions

